

Nome	Classe	UNI	DIN	EN ISO	Pag.
Viti T.C.E.I. passo grosso Socket head cap screws	8.8	5931	912	4762	2.1 - 2.2
Viti T.C.E.I. stampate a caldo, passo grosso Socket head cap screws, hot forging	8.8	5931	912	4762	2.3
Viti T.C.E.I. passo grosso Socket head cap screws	10.9	5931	912	4762	2.4
Viti T.C.E.I. passo grosso Socket head cap screws	12.9	5931	912	4762	2.5
Viti T.S.P.E.I. passo grosso Countersunk socket head screws	10.9	5933	7991-A	10642	2.6 - 2.7
Viti T.B.E.I. passo grosso Socket button head cap screws	10.9			7380	2.8 - 2.9
Grani con esagono incassato a punta piana, passo grosso Socket set screws, with flat point	45H (14.9)	5923	913		2.10
Grani con esagono incassato a punta cilindrica, passo grosso Socket set screws, with dog point	45H (14.9)	5925	915		2.10
Grani con esagono incassato a punta conica, passo grosso Socket set screws, with cone point	45H (14.9)	5927	914		2.11
Grani con esagono incassato a punta a coppa, passo grosso Socket set screws, with cup point	45H (14.9)	5929	916		2.11

VITI A TESTA CILINDRICA

con esagono incassato

Classe 8.8

SOCKET HEAD CAP SCREWS

Property Class 8.8

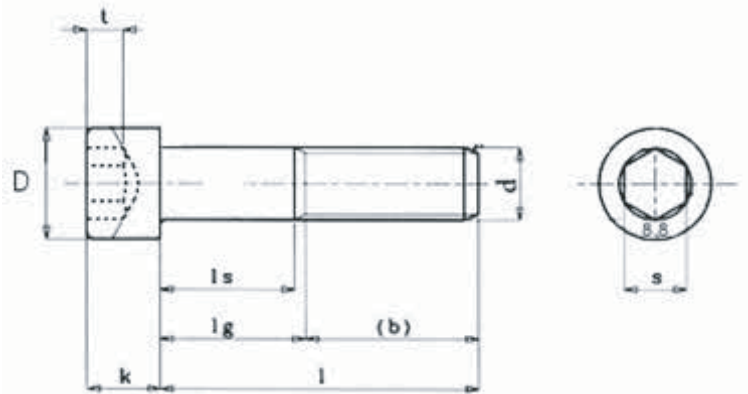

ART.10AD/50

FILETTATURA METRICA A PASSO GROSSO / Metric Coarse Pitch Thread

UNI 5931 DIN 912 EN ISO 4762

Passo fil.	0,7	0,8	1	1,25	1,5	1,75	2	2	2,5	2,5	3
D	7	8,5	10	13	16	18	21	24	27	30	36
k	4	5	6	8	10	12	14	16	18	20	24
t max	2,4	3,1	3,78	4,78	6,25	7,5	8,7	9,7	10,7	11,8	14
b	20	22	24	28	32	36	40	44	48	52	60
s	3	4	5	6	8	10	12	14	14	17	19

lg.max. = 1 (b) , ls.min. = lg.max. 5 volte il passo

PREZZI € PER 100 PEZZI / PRICE € PER 100 PIECES

d	4	5	6	8	10	12	14	16	18	20	24
8	4,60	4,95	5,80								
10	3,80	4,00	5,30	8,60							
12	3,45	3,70	4,60	8,45							
14	3,45	3,90	4,70	8,45							
16	3,35	3,65	4,70	8,35	16,30						
18	3,55	3,85	5,40	8,70	24,05						
20	3,55	3,85	5,40	8,70	17,00	23,10					
25	4,05	4,50	6,10	9,65	18,65	25,40	47,80				
30	4,35	5,05	6,65	10,70	20,05	27,55	44,65	55,40			
35	5,15	5,85	7,55	12,90	21,40	29,40	47,80	59,30			
40	5,80	6,70	8,40	13,65	22,85	31,00	48,95	60,80	100,20	100,20	234,35
45	8,30	7,45	9,25	14,70	24,30	33,35	49,55	61,50	101,40	101,40	230,30
50		9,05	11,30	15,55	26,00	35,65	53,80	66,80	108,40	108,40	187,65
55			12,75	16,90	27,75	38,25	57,80	74,10	118,95	118,95	197,60
60		11,55	14,55	17,80	29,60	41,45	63,00	77,85	123,80	123,80	206,35
65											
70		14,90	18,65	21,60	34,95	49,95	71,20	87,25	136,55	136,55	249,30
75											
80			24,40	27,35	40,55	58,05	79,40	96,35	150,80	150,80	281,60
90			27,75	33,90	45,95	65,85	89,20	106,45	166,55	166,55	310,45
100			31,25	39,95	51,80	78,15	97,60	118,60	185,55	185,55	352,25
110			36,10	44,50	59,55	89,45	107,75	128,75	201,40	201,40	384,95
120			41,80	48,75	68,00	101,00	121,10	142,70	223,20	223,20	416,30
130				54,95	75,15	115,35	135,20	157,25	246,00	246,00	446,05
140				58,55	82,95	130,20	160,70	196,65	294,45	294,45	478,35
150				73,70	92,00	143,75	183,40	209,15	327,10	327,10	541,30
160					102,75	157,30	205,70	234,95		367,40	603,30
180							237,75	285,70		439,70	707,30
200							278,80	337,95		518,95	829,95
220							328,35	376,15		575,75	
240							377,60	432,50		644,75	
260							434,25	497,40		722,10	
280							499,35	572,00		808,80	

LE MISURE SOPRA LA LINEA SONO INTERAMENTE FILETTATE

ABOVE THE BOLD LINE FULLY THREADED

Materiale: Cl.8.8 secondo UNI EN 20898 - 1
 Carico di rottura a trazione: minimo 800 N/mm²
 Limite di elasticità minimo: 640 N/mm²
 Allungamento minimo: 12%
 Tolleranza: categoria "A" e "B" ISO 4759/1
 Trattamento superficiale: grezze/oleate

Property Class: 8.8 Steel as per UNI EN 20898 - 1
 Tensile Strength: Min 800 N/mm²
 Stress at 0,2% non proportional elongation: 640 N/mm²
 Percentage elongation: 12%
 Tolerance: Cat "A" and "B" as per ISO 4759/1
 Surface Treatment: no finish/oiled

VITI A TESTA CILINDRICA

con esagono incassato

Classe 8.8 zincate

SOCKET HEAD CAP SCREWS

Property Class 8.8 ZPCr3

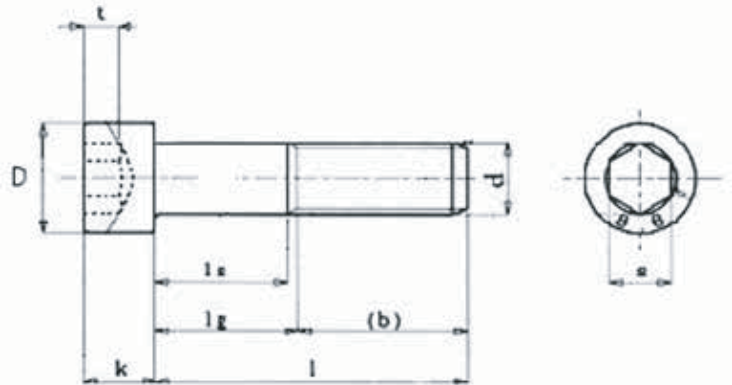

ART.10AD/3U

FILETTATURA METRICA A PASSO GROSSO / Metric Coarse Pitch Thread

UNI 5931 DIN 912 EN ISO 4762

Passo fil.	0,7	0,8	1	1,25	1,5	1,75	2	2	2,5	2,5	3
D	7	8,5	10	13	16	18	21	24	27	30	36
k	4	5	6	8	10	12	14	16	18	20	24
t max	2,4	3,1	3,78	4,78	6,25	7,5	8,7	9,7	10,7	11,8	14
b	20	22	24	28	32	36	40	44	48	52	60
s	3	4	5	6	8	10	12	14	14	17	19

lg.max. = 1 (b) , ls.min. = lg.max. 5 volte il passo

PREZZI € PER 100 PEZZI / PRICE € PER 100 PIECES

d	4	5	6	8	10	12	14	16	18	20	24
8	4,75	5,15	6,20								
10	3,95	4,25	5,70	9,45							
12	3,65	3,95	5,00	9,40							
14	3,65	4,20	5,20	9,45							
16	3,55	3,90	5,20	9,35	18,05						
18	3,80	4,15	5,95	9,80	25,85						
20	3,80	4,20	6,00	9,85	18,95	25,85					
25	4,30	4,90	6,75	10,90	20,80	28,45	51,90				
30	4,70	5,50	7,35	12,15	22,45	30,90	49,15	62,05			
35	5,50	6,40	8,40	14,50	24,00	33,10	52,75	66,55			
40	6,20	7,30	9,35	15,45	25,70	35,00	54,35	68,55	113,00	113,00	257,40
45	8,75	8,15	10,25	16,65	27,35	37,65	55,35	69,85	115,15	115,15	254,65
50		9,80	12,45	17,70	29,40	40,30	60,05	75,85	123,10	123,10	213,30
55			13,95	19,20	31,40	43,30	64,50	83,85	134,60	134,60	224,65
60			12,45	15,85	20,30	33,50	46,85	70,20	88,30	140,40	234,55
65											
70			15,90	20,15	24,40	39,40	56,05	79,40	99,05	155,00	280,30
75											
80			26,10	30,50	45,50	64,90	88,65	109,50	171,40	171,40	315,70
90			29,60	37,35	51,45	73,50	99,45	120,95	189,25	189,25	347,65
100			33,30	43,75	57,85	86,55	108,85	134,50	210,40	210,40	392,50
110			38,35	48,65	66,10	98,60	120,05	146,00	228,40	228,40	428,30
120			44,25	53,20	75,05	110,90	134,45	161,30	252,35	252,35	462,75
130				59,80	82,75	126,00	149,55	177,25	277,25	277,25	495,55
140				63,70	91,05	141,65	176,10	218,05	327,90	327,90	530,90
150				79,20	100,65	155,95	199,80	231,90	362,65	362,65	596,90
160					111,95	170,30	223,15	259,05		405,10	662,05
180							257,25	312,55		481,70	772,20
200							300,35	367,55		565,20	900,95
220											
240											
260											
280											

LE MISURE SOPRA LA LINEA SONO INTERAMENTE FILETTATE

ABOVE THE BOLD LINE FULLY THREADED

Materiale: Cl.8.8 secondo UNI EN 20898 - 1
 Carico di rottura a trazione: minimo 800 N/mm²
 Limite di elasticità minimo: 640 N/mm²
 Allungamento minimo: 12%
 Tolleranza: categoria "A" e "B" ISO 4759/1
 Trattamento superficiale: zincatura bianca secondo ISO 4042

Property Class: 8.8 Steel as per UNI EN 20898 - 1
 Tensile Strength: Min 800 N/mm²
 Stress at 0,2% non proportional elongation: 640 N/mm²
 Percentage elongation: 12%
 Tolerance: Cat "A" and "B" as per ISO 4759/1
 Surface Treatment: ZPCr3 as per ISO 4042

VITI A TESTA CILINDRICA

con esagono incassato

Classe 8.8 (STAMPATE A CALDO)

SOCKET HEAD CAP SCREWS

Property Class 8.8 (Hot Forging)

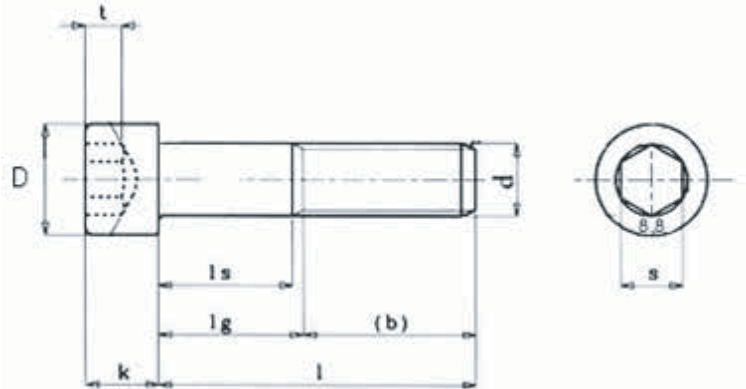

ART.10AD/50

FILETTATURA METRICA A PASSO GROSSO / Metric Coarse Pitch Thread

UNI 5931 DIN 912 EN ISO 4762

Passo fil.	2,5	3	3	3,5	3,5	4	4	4,5
D	33	36	40	45	50	54	58	63
k	22	24	27	30	33	36	39	42
t max	12,4	14	16,2	18,2				
b (l<125)	50	54	60	66				
b (125<200)	56	60	66	72	78	84	90	96
b (l>200)			79	85				
S	17	19	19	22	24	27	27	32

lg.max. = 1 (b) , ls.min. = lg.max. 5 volte il passo

PREZZI € PER 100 PEZZI / PRICE € PER 100 PIECES

d	22	24	27	30	33	36	39	42
50	187,65		719,50	780,00				
55	197,60		719,50	780,00				
60	206,35		719,50	780,00				
65	235,75		719,50	780,00				
70	249,30		719,50	780,00	1.197,45	1.363,20		
80	281,60		757,21	828,75	1.197,45	1.363,20		
90	310,45		848,60	877,40	1.251,80	1.402,45	1.948,45	
100	352,25		858,40	926,15	1.306,60	1.459,65	1.948,45	2.302,60
110	384,95		895,70	975,35	1.398,50	1.554,30	2.014,00	2.374,55
120	416,30		934,60	1.023,65	1.455,45	1.628,90	2.079,50	2.448,25
130	446,05		970,45	1.072,35	1.509,90	1.705,35	2.209,00	2.558,80
140	478,35		1.010,00	1.121,25	1.564,70	1.780,00	2.274,50	2.704,50
150	541,30		1.049,85	1.170,00	1.619,50	1.857,45	2.338,45	2.813,30
160	603,30		1.089,15	1.218,70	1.676,10	1.932,85	2.404,00	2.923,85
180	707,30		1.170,00	1.316,10	1.785,70	2.083,90	2.533,45	3.143,25
200	829,95		1.254,00	1.462,40	1.914,80	2.236,80	2.664,50	3.362,60
220	899,50	899,90	1.370,75	1.527,45	2.061,50	2.349,65	2.794,00	3.508,25
240	989,45	989,45	1.487,55	1.608,60	2.208,25	2.462,50	2.923,45	3.555,70
260	1.088,40	1.088,40	1.604,55	1.722,35	2.355,80	2.577,16	3.085,70	3.838,20
280	1.197,25	1.197,25	1.721,55	1.835,95	2.503,50	2.750,05	3.249,50	4.020,75
300	1.316,95	1.310,95	1.838,05	1.950,00	2.650,25	2.913,05	3.411,75	4.240,10
320	*	*	*	*	*	*	*	*
340	*	*	*	*	*	*	*	*
360	*	*	*	*	*	*	*	*
380	*	*	*	*	*	*	*	*
400	*	*	*	*	*	*	*	*

* = Prezzi a richiesta

LE MISURE SOPRA LA LINEA SONO INTERAMENTE FILETTATE

* = Prices on demand

ABOVE THE BOLD LINE FULLY THREADED

* Non applicabile alle viti con filettatura M27
 Materiale: Cl.8.8 secondo UNI EN 20898 - 1
 Carico di rottura a trazione: minimo 800 N/mm²
 Limite di elasticità minimo: 640 N/mm²
 Allungamento minimo: 12%
 Tolleranza: categoria "A" e "B" ISO 4759/1
 Trattamento superficiale: grezze/oleate

* Not applicable on screw with M27 thread
 Property Class: 8.8 Steel as per UNI EN 20898 - 1
 Tensile Strength: Min 800 N/mm²
 Stress at 0,2% non proportional elongation: 640 N/mm²
 Percentage elongation: 12%
 Tolerance: Cat "A" and "B" as per ISO 4759/1
 Surface Treatment: no finish/oiled

VITI A TESTA CILINDRICA
 con esagono incassato
 Classe 10.9
SOCKET HEAD CAP SCREWS
 Property Class 10.9

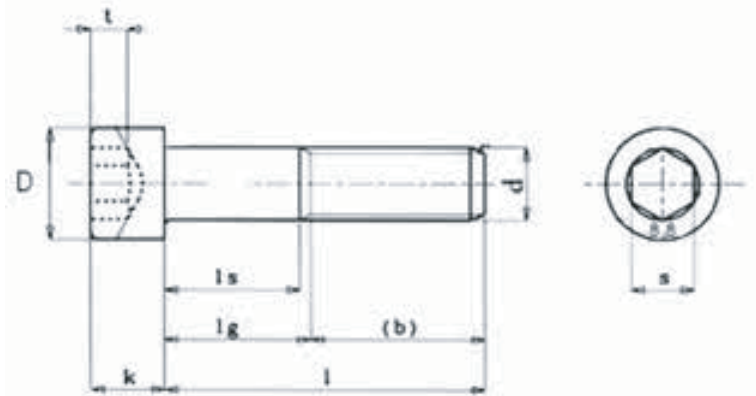

ART.10AE/50

FILETTATURA METRICA A PASSO GROSSO / Metric Coarse Pitch Thread

UNI 5931 DIN 912 EN ISO 4762

Passo fil.	1	1,25	1,5	1,75	2	2,5	3
D	10	13	16	18	24	30	36
k	6	8	10	12	16	20	24
s	5	6	8	10	14	17	19
t min	3	4	5	6	8	10	12
b	24	28	32	36	44	52	60

lg.max. = 1 (b) , ls.min. = lg.max. 5 volte il passo

PREZZI € PER 100 PEZZI / PRICE € PER 100 PIECES

d	6	8	10	12	16	20	24
16	5,40	9,55	18,70				
20	6,25	10,00	19,55	26,55			
25	7,00	11,05	21,45	29,20	60,70		
30	7,65	12,30	23,10	31,65	63,70		
35	8,65	14,85	24,65	33,85	68,20	124,35	
40	9,70	15,70	26,30	35,65	69,90	115,20	269,50
45	10,60	16,90	27,90	38,35	70,70	116,60	264,85
50	13,00	17,90	29,90	41,00	76,80	124,65	215,80
55		19,40	31,90	44,00	85,25	136,80	227,25
60		20,50	34,05	47,65	89,55	142,40	237,30
65			37,05	53,70	95,25	150,20	271,10
70			40,20	57,40	100,30	157,00	286,65
80			46,60	66,75	110,80	173,40	323,85
90				75,75	122,40	191,50	357,05
100				89,85	136,40	213,35	405,10
110					148,05	231,60	442,70
120					164,10	256,65	478,75

LE MISURE SOPRA LA LINEA SONO INTERAMENTE FILETTATE

ABOVE THE BOLD LINE FULLY THREADED

Materiale: Cl.10.9 secondo UNI EN 20898 - 1
 Carico di rottura a trazione: minimo 1000 N/mm²
 Limite di elasticità minimo: 900 N/mm²
 Allungamento minimo: 9%
 Tolleranza: categoria "A" e "B" ISO 4759/1
 Trattamento superficiale: grezze/oleate

Property Class: 10.9 Steel as per UNI EN 20898 - 1
 Tensile Strength: Min 1000 N/mm²
 Stress at 0,2% non proportional elongation: 900 N/mm²
 Percentage elongation: 9%
 Tolerance: Cat "A" and "B" as per ISO 4759/1
 Surface Treatment: no finish/oiled

VITI A TESTA CILINDRICA

con esagono incassato

Classe 12.9

SOCKET HEAD CAP SCREWS

Property Class 12.9

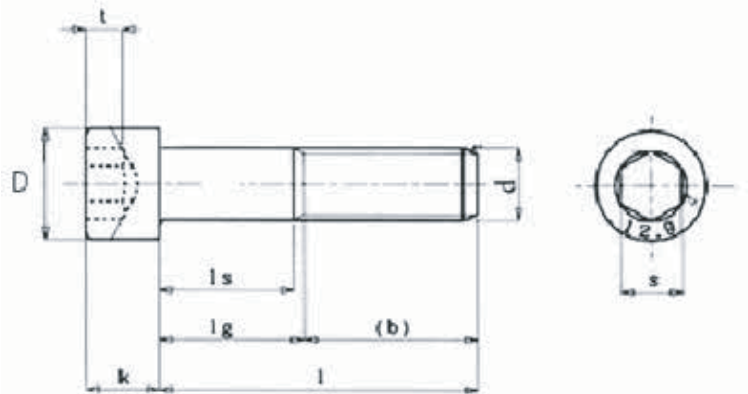

ART.10AF/50

FILETTATURA METRICA A PASSO GROSSO / Metric Coarse Pitch Thread

UNI 5931 DIN 912 EN ISO 4762

Passo fil.	0,7	0,8	1	1,25	1,5	1,75	2	2	2,5	3
D	7	8,5	10	13	16	18	21	24	30	36
k	4	5	6	8	10	12	14	16	20	24
t max	2,4	3,1	3,78	4,78	6,25	7,5	8,7	9,7	11,8	14
b (l<125)	14	16	18	22	26	30	34	38	46	54
b (125<200)	20	22	24	28	32	36	40	44	52	60
b (l>200)										
S	3	4	5	6	8	10	12	14	17	19

lg.max. = 1 (b) , ls.min. = lg.max. 5 volte il passo

PREZZI € PER 100 PEZZI / PRICE € PER 100 PIECES

d	4	5	6	8	10	12	14	16	20	24
8	5,75	6,20								
10	4,70	5,00	6,60							
12	4,30	4,60	5,75							
14	4,30	4,90	5,90							
16	4,20	4,55	5,90	10,40	20,35					
18	4,45	4,80	6,75	10,85						
20	4,45	4,80	6,75	10,85	21,25	28,85				
25	5,05	5,65	7,60	12,05	23,30	31,75				
30	5,45	6,30	8,30	13,40	25,10	34,40	55,80	69,25		
35	6,40	7,35	9,45	16,15	26,75	36,75	59,75	74,15		
40	7,25	8,35	10,50	17,05	28,60	38,75	61,20	75,95	125,20	
45		9,35	11,55	18,35	30,35	41,70	61,90	76,85	126,75	
50		11,30	14,15	19,45	32,50	44,55	67,25	83,50	135,45	234,55
55			15,90	21,10	34,70	47,80	72,25	92,65	148,70	247,00
60			18,15	22,25	37,00	51,80	78,75	97,35	154,75	257,90
70			23,30	27,00	43,70	62,40	89,00	109,05	170,65	311,60
80			30,50	34,20	50,65	72,55	99,25	120,45	188,50	352,00
90			34,65	42,35	57,40	82,30	111,45	133,05	208,15	388,10
100			39,05	49,95	64,75	97,70	121,95	148,25	231,90	440,30
110			45,15	55,60	74,40	111,80	134,65	160,90	251,75	481,20
120			52,25	60,90	85,00	126,25	151,35	178,35	279,00	520,40
130				68,65	93,90	144,15	169,00	196,60	307,45	557,60
140				73,20	103,70	162,70	200,85	245,85	368,10	597,95
150				92,10	115,00	179,70	229,25	261,45	408,90	676,60

LE MISURE SOPRA LA LINEA SONO INTERAMENTE FILETTATE

ABOVE THE BOLD LINE FULLY THREADED

Materiale: Cl.12.9 secondo UNI EN 20898 - 1
 Carico di rottura a trazione: minimo 1200 N/mm²
 Limite di elasticità minimo: 1080 N/mm²
 Allungamento minimo: 8%
 Tolleranza: categoria "A" e "B" ISO 4759/1
 Trattamento superficiale: grezze/oleate

Property Class: 12.9 Steel as per UNI EN 20898 - 1
 Tensile Strength: Min 1200 N/mm²
 Stress at 0,2% non proportional elongation: 1080 N/mm²
 Percentage elongation: 8%
 Tolerance: Cat "A" and "B" as per ISO 4759/1
 Surface Treatment: no finish/oiled

VITI A TESTA SVASATA PIANA
 con esagono incassato
 Classe 10.9
COUNTERSUNK SOCKET HEAD SCREWS
 Property Class 10.9

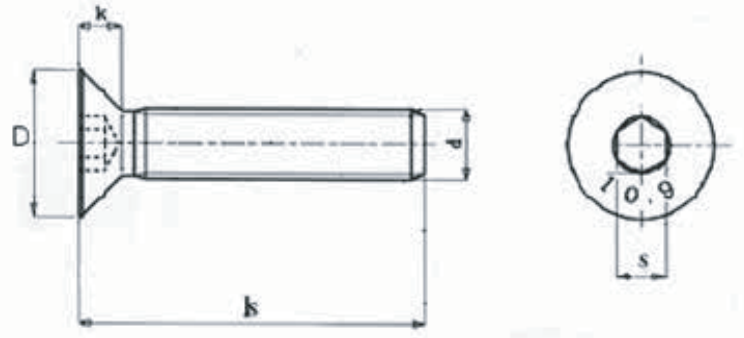

ART.111E/50

FILETTATURA METRICA A PASSO GROSSO / Metric Coarse Pitch Thread

UNI 5933 DIN 7991-A EN 10642

Passo fil.	0,5	0,7	0,8	1	1,25	1,5	1,75	2	2	2,5
D	6	8	10	12	16	20	24	27	30	36
K	1,7	2,3	2,8	3,3	4,4	5,5	6,5	7	7,5	8,5
s	2	2,5	3	4	5	6	8	10	10	12

PREZZI € PER 100 PEZZI / PRICE € PER 100 PIECES

d	3	4	5	6	8	10	12	14	16	20
8	4,70	4,70								
10	4,20	3,95	4,25	5,65						
12	4,40	3,65	3,95	5,00						
14		3,65	4,25	5,20						
16	4,55	3,55	4,00	5,25	9,35	23,30				
18										
20	5,05	3,80	4,30	6,05	9,90	18,90	33,80			
25		4,35	5,00	6,80	11,05	20,90	34,55			
30		4,75	5,65	7,50	12,30	22,70	31,45	64,70	62,50	
35		5,55	6,55	8,50	14,75	24,35	33,80	69,25	67,30	
40		6,30	8,95	9,50	15,65	26,15	35,90	72,10	69,70	171,20
45				10,40	16,95	27,90	38,75	73,70	71,30	175,30
50			15,20	12,65	18,00	30,00	41,55	80,20	77,55	187,80
55				17,00	19,50	32,10	44,60	86,25	85,75	205,70
60				21,70	20,65	34,30	48,30	93,90	90,45	215,05
70				30,50	24,65	39,95	57,30	139,00	132,10	238,45
80					34,00	52,80	68,65	166,10	155,85	258,70
90					66,20	73,95				
100					98,50	113,20				

Materiale: Cl.10.9 secondo UNI EN 20898 - 1
 Carico di rottura a trazione: minimo 1000 N/mm²
 Limite di elasticità minimo: 900 N/mm²
 Allungamento minimo: 9%
 Tolleranza: categoria "A" e "B" ISO 4759/1
 Trattamento superficiale: grezze/oleate

Property Class: 10.9 Steel as per UNI EN 20898 - 1
 Tensile Strength: Min 1000 N/mm²
 Stress at 0,2% non proportional elongation: 900 N/mm²
 Percentage elongation: 9%
 Tollerance: Cat "A" and "B" as per ISO 4759/1
 Surface Treatment: no finish/oiled

VITI A TESTA SVASATA PIANA

con esagono incassato

Classe 10.9 zincate

COUNTERSUNK SOCKET HEAD SCREWS

Property Class 10.9 ZPCr3

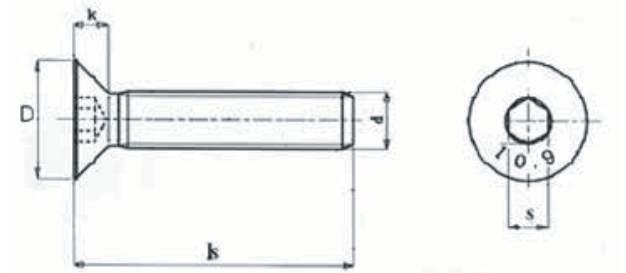

ART.111E/3U

FILETTATURA METRICA A PASSO GROSSO / Metric Coarse Pitch Thread

UNI 5933 DIN 7991-A EN 10642

Passo fil.	0,5	0,7	0,8	1	1,25	1,5	1,75	2	2	2,5
D	6	8	10	12	16	20	24	27	30	36
K	1,7	2,3	2,8	3,3	4,4	5,5	6,5	7	7,5	8,5
s	2	2,5	3	4	5	6	8	10	10	12

PREZZI € PER 100 PEZZI / PRICE € PER 100 PIECES

d	3	4	5	6	8	10	12	14	16	20
8	4,85	4,85								
10	4,35	4,10	4,55	6,10						
12	4,55	3,85	4,35	5,55						
14		3,90	4,65	5,75						
16	4,75	3,85	4,45	5,85	10,60	25,40				
18										
20	5,25	4,15	4,80	6,80	11,45	21,35	37,40			
25		4,75	5,65	7,75	12,75	23,75	38,80			
30		5,20	6,40	8,60	14,30	25,95	36,30	71,15	71,35	
35		6,05	7,40	9,75	17,00	28,05	39,30	76,05	77,30	
40		6,85	9,90	10,90	18,20	30,30	42,00	80,20	80,80	188,60
45				11,90	19,70	32,45	45,45	82,70	83,55	194,60
50			16,50	14,30	21,05	35,00	48,85	90,00	90,95	208,80
55				18,80	22,80	37,50	52,55	96,95	100,30	228,45
60				23,65	24,20	40,10	56,85	105,45	106,10	239,50
70				32,60	28,50	46,20	66,45	152,25	150,10	266,45
80					41,50	67,50	89,70	183,15	184,00	299,50
90					75,90	85,50				
100					110,90	132,00				

Materiale: Cl.10.9 secondo UNI EN 20898 - 1
 Carico di rottura a trazione: minimo 1000 N/mm²
 Limite di elasticità minimo: 900 N/mm²
 Allungamento minimo: 9%
 Tolleranza: categoria "A" e "B" ISO 4759/1
 Trattamento superficiale: zincatura bianca e deidrogenizzazione secondo ISO 4042

Property Class: 10.9 Steel as per UNI EN 20898 - 1
 Tensile Strength: Min 1000 N/mm²
 Stress at 0,2% non proportional elongation: 900 N/mm²
 Percentage elongation: 9%
 Tolerance: Cat "A" and "B" as per ISO 4759/1
 Surface Treatment: ZPCr3 and Dehydrogenated as per ISO 4042

VITI CON TESTA BOMBATA

con esagono incassato

Classe 10.9

SOCKET BUTTON HEAD CAP SCREWS

Property Class 10.9

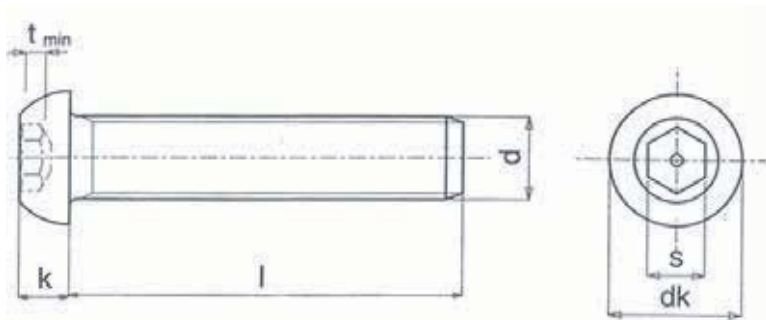

ART.041E/50

FILETTATURA METRICA A PASSO GROSSO / Metric Coarse Pitch Thread

EN ISO 7380

Passo fil.	0,5	0,7	0,8	1	1,25	1,5	1,75
dk	5,7	7,6	9,5	10,5	14	17,5	21
k	1,65	2,2	2,75	3,3	4,4	5,5	6,6
s	2	2,5	3	4	5	6	8
t min	1,04	1,3	1,56	2,08	2,6	3,12	4,16

PREZZI € PER 100 PEZZI / PRICE € PER 100 PIECES

d	3x0,5	4x0,7	5x0,8	6x1	8x1,25	10x1,5	12x1,75
8		4,75	5,20	10,50			
10		3,95	4,30	5,70	13,20		
12		3,65	4,00	5,05	11,25		
16		3,60	4,00	5,30	9,40	23,80	
20		3,85	4,30	6,05	9,95	19,25	31,75
25		4,35	5,05	6,85	11,10	21,25	29,30
30		5,70	5,65	7,50	12,40	22,90	32,00
35		6,65	7,90	8,55	14,85	24,65	34,35
40		7,55	9,70	9,55	15,75	26,80	36,45
45			12,45	10,45	17,05	28,25	39,20
50			15,00	12,65	18,15	30,30	42,00
55				17,00	19,60	32,40	45,10
60				22,55	24,90	34,25	58,50
70					30,70	40,50	69,85

Materiale: Cl.10.9 secondo UNI EN 20898 - 1
 Carico di rottura a trazione: minimo 1000 N/mm²
 Limite di elasticità minimo: 900 N/mm²
 Allungamento minimo 9%
 Tolleranza: categoria "A" e "B" ISO 4759/1
 Trattamento superficiale: grezze/oleate

Property Class: 10.9 Steel as per UNI EN 20898 - 1
 Tensile Strength: Min 1000 N/mm²
 Stress at 0,2% non proportional elongation: 900 N/mm²
 Percentage elongation: 9%
 Tolerance: Cat "A" and "B" as per ISO 4759/1
 Surface Treatment: no finish/oiled

VITI CON TESTA BOMBATA

con esagono incassato

Classe 10.9 zincate

SOCKET BUTTON HEAD CAP SCREWS

Property Class 10.9 ZPCr3

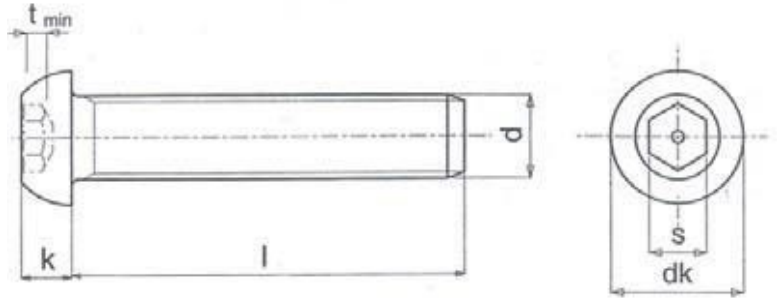

ART.041E/3U

FILETTATURA METRICA A PASSO GROSSO / Metric Coarse Pitch Thread

EN ISO 7380

Passo fil.	0,5	0,7	0,8	1	1,25	1,5	1,75
dk	5,7	7,6	9,5	10,5	14	17,5	21
k	1,65	2,2	2,75	3,3	4,4	5,5	6,6
s	2	2,5	3	4	5	6	8
t min	1,04	1,3	1,56	2,08	2,6	3,12	4,16

PREZZI € PER 100 PEZZI / PRICE € PER 100 PIECES

d	3x0,5	4x0,7	5x0,8	6x1	8x1,25	10x1,5	12x1,75
8		4,95	5,50	10,95			
10		4,15	4,60	6,25	14,25		
12		3,90	4,40	5,65	12,45		
16		3,85	4,45	6,00	10,80	26,40	
20		4,15	4,85	6,90	11,50	22,15	36,00
25		4,75	5,70	7,85	12,95	24,55	34,20
30		6,15	6,40	8,60	14,55	26,40	37,65
35		7,15	8,75	9,80	17,25	28,70	40,55
40		8,15	10,65	11,00	18,40	31,65	43,25
45			13,50	12,00	19,95	33,20	46,55
50			16,15	14,30	21,40	35,65	49,90
55				18,85	23,05	38,20	53,65
60				24,50	28,55	40,05	67,60
70					35,70	47,40	80,15

Materiale: Cl. 10.9 secondo UNI EN 20898 - 1
 Carico di rottura a trazione: minimo 1000 N/mm²
 Limite di elasticità minimo: 900 N/mm²
 Allungamento minimo 9%
 Tolleranza: categoria "A" e "B" ISO 4759/1
 Trattamento superficiale: zincatura e deidrogenizzazione secondo ISO 4042

Property Class: 10.9 Steel as per UNI EN 20898 - 1
 Tensile Strength: Min 1000 N/mm²
 Stress at 0,2% non proportional elongation: 900 N/mm²
 Percentage elongation: 9%
 Tolerance: Cat "A" and "B" as per ISO 4759/1
 Surface Treatment: ZPCr3 and Dehydrogenated as per ISO 4042

VITI SENZA TESTA (GRANI)

con esagono incassato a punta piana

Classe 45H (14.9)

SOCKET SET SCREWS

With Flat Point

Property Class 45H (14.9)

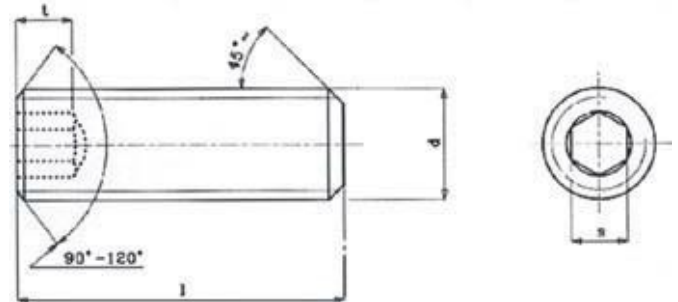

ART.151F/50

FILETTATURA METRICA A PASSO GROSSO / Metric Coarse Pitch Thread

UNI 5923 DIN 913

Passo fil.	0,5	0,7	0,8	1	1,25	1,5	1,75	2	2	2,5	2,5	2,5	3
t	2	2,5	3	3,5	5	6	8	9	10	11	12	13,5	15
s	1,5	2	2,5	3	4	5	6	6	8	10	10	12	12

PREZZI € PER 100 PEZZI / PRICE € PER 100 PIECES

d	3	4	5	6	8	10	12	14	16	18	20	22	24
3	4,84	5,94											
4	4,62	4,51	7,37	8,58									
5	4,62	4,51	4,51	6,05									
6	4,73	4,40	4,51	4,84	8,69								
8	4,84	4,40	4,73	4,95	6,60	14,74							
10	5,50	4,51	4,84	5,17	7,04	12,76	23,10						
12	6,05	4,84	5,17	6,05	7,92	13,75	19,80						
14	8,80	6,49	6,49	7,59	10,01	16,94	22,55	71,28					
16	8,69	5,61	6,16	7,04	10,01	16,17	22,44	73,04	60,72				
20	10,34	7,37	8,14	8,47	11,55	18,26	26,51	77,88	82,61		236,17		
25	16,50	15,62	11,11	11,55	15,18	21,78	30,47	83,38	90,20		276,32		
30	15,84	15,95	15,95	15,29	18,04	25,52	36,19	89,54	98,23		304,48		
35		17,60	17,16	17,49	21,34	29,26	43,34	0,00	107,03		0,00		
40		19,69	18,59	19,80	23,98	33,77	47,85	102,08	114,51		414,26		
45		0,00	21,56	20,79	29,04	40,81	56,65	0,00	122,65		0,00		
50		0,00	24,20	23,43	31,90	46,09	59,73	113,08	130,24		0,00		
60		0,00	0,00	36,63	45,76	77,77	87,34	0,00	153,67		414,26		

VITI SENZA TESTA (GRANI)

con esagono incassato a punta cilindrica

Classe 45H (14.9)

SOCKET SET SCREWS

With Dog Point

Property Class 45H (14.9)

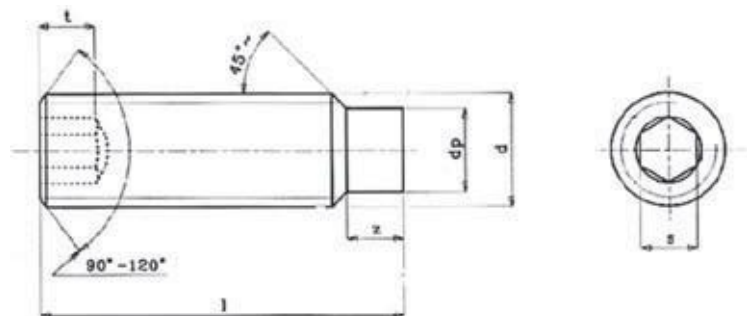

ART.161F/50

FILETTATURA METRICA A PASSO GROSSO / Metric Coarse Pitch Thread

UNI 5925 DIN 915

d	3	4	5	6	8	10	12	14	16	18	20	22	24
Passo fil.	0,5	0,7	0,8	1	1,25	1,5	1,75	2	2	2,5	2,5	2,5	3
t	2	2,5	3	3,5	5	6	8	9	10	11	12	13,5	15
s	1,5	2	2,5	3	4	5	6	6	8	10	10	12	12

Prezzi a richiesta

Prices on Demand

Materiale: Cl.45H (14.9) secondo ISO 7323/10
 Carico di rottura a trazione minimo: 1400 N/mm²
 Limite di elasticità minimo: 1260 N/mm²
 Tolleranza: categoria "A" e "B" ISO 4759/1
 Trattamento superficiale: grezze/oleate

Property Class: 45H (14.9) as per ISO 7323/10
 Tensile Strength: Min 1400 N/mm²
 Stress at 0,2% non proportional elongation: 1260 N/mm²
 Tolerance: Cat "A" and "B" as per ISO 4759/1
 Surface Treatment: no finish/oiled

VITI SENZA TESTA (GRANI)

con esagono incassato a punta conica

Classe 45H (14.9)

SOCKET SET SCREWS

With Cone Point

Property Class 45H (14.9)

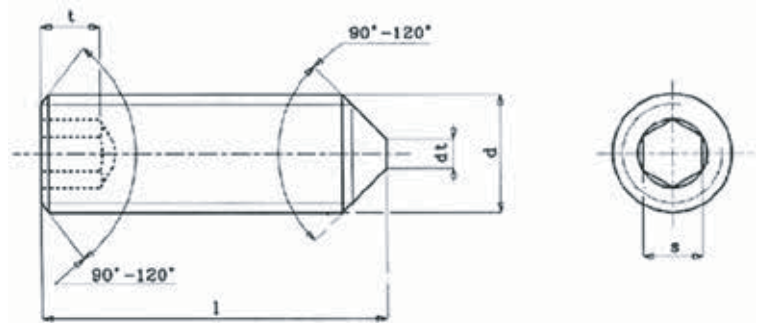

ART.171F/50

FILETTATURA METRICA A PASSO GROSSO / Metric Coarse Pitch Thread

UNI 5927 DIN 914

Passo fil.	0,5	0,7	0,8	1	1,25	1,5	1,75	2	2	2,5	2,5	2,5	3
t	2	2,5	3	3,5	5	6	8	9	10	11	12	13,5	15
s	1,5	2	2,5	3	4	5	6	6	8	10	10	12	12

PREZZI € PER 100 PEZZI / PRICE € PER 100 PIECES

d	3	4	5	6	8	10	12	14	16	18	20	22	24
3	6,05												
4	5,06	5,50	7,15										
5	5,06	4,62	5,61	8,36									
6	5,17	4,73	4,84	6,05									
8	5,50	5,06	5,39	5,61	7,59								
10	6,05	5,28	5,50	5,72	7,59	14,74	26,84						
12	6,82	5,72	6,05	6,49	8,91	15,07	24,09						
14	9,68	6,93	7,26	8,03	11,11	18,37	0,00						
16	9,68	6,93	6,93	7,59	11,11	17,60	25,30						
20	11,33	8,25	9,13	9,35	12,98	20,13	29,37						
25	17,16	16,39	12,76	13,20	17,05	23,87	34,10						
30	17,60	16,94	17,38	17,05	21,45	28,05	40,15						
35			20,13	20,13	23,76	32,56	0,00						
40				22,44	26,62	37,18	53,02						
45					34,76	44,88	0,00						
50					36,52	50,49	67,54						
60					48,73		99,88						
70													
80							160,82						

l = lunghezza/length mm

VITI SENZA TESTA (GRANI)

con esagono incassato a punta a coppa

Classe 45H (14.9)

SOCKET SET SCREWS

With Cup Point

Property Class 45H (14.9)

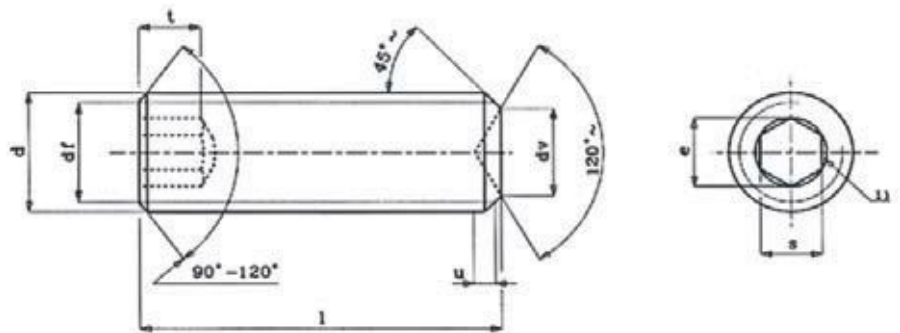

ART.181F/50

FILETTATURA METRICA A PASSO GROSSO / Metric Coarse Pitch Thread

UNI 5929 DIN 916

d	3	4	5	6	8	10	12	14	16	18	20	22	24
Passo fil.	0,5	0,7	0,8	1	1,25	1,5	1,75	2	2	2,5	2,5	2,5	3
t	2	2,5	3	3,5	5	6	8	9	10	11	12	13,5	15
s	1,5	2	2,5	3	4	5	6	6	8	10	10	12	12

Prezzi a richiesta

Prices on Demand

Materiale: Cl.45H (14.9) secondo ISO 7323/10
 Carico di rottura a trazione minimo: 1400 N/mm²
 Limite di elasticità minimo: 1260 N/mm²
 Tolleranza: categoria "A" e "B" ISO 4759/1
 Trattamento superficiale: grezze/oleate

Property Class: 45H (14.9) as per ISO 7323/10
 Tensile Strength: Min 1400 N/mm²
 Stress at 0,2% non proportional elongation: 1260 N/mm²
 Tolerance: Cat "A" and "B" as per ISO 4759/1
 Surface Treatment: no finish/oiled